

**INQUIRIES**

**Kawasaki Heavy Industries, Ltd.**

**ROBOT DIVISION**

<http://www.khi.co.jp/robot/>

**Tokyo Head Office/Robot Division**

1-14-5 Kaigan, Minato-ku, Tokyo 105-8315, Japan  
Phone: +81-3-3435-6852 Fax: +81-3-3437-9880

**Akashi Works/Robot Division**

1-1, Kawasaki-cho, Akashi, Hyogo 673-8666, Japan  
Phone: +81-78-921-2946 Fax: +81-78-923-6548

**Kawasaki Robotics (U.S.A.), Inc.**

[www.kawasakirobot.com](http://www.kawasakirobot.com)  
28140 Lakeview Drive, Wixom, MI 48393, U.S.A.  
Phone: +1-248-446-4100 Fax: +1-248-446-4200

**Kawasaki Robotics (UK) Ltd.**

[www.kawasakirobot.co.uk/](http://www.kawasakirobot.co.uk/)  
Unit 4 Easter Court, Europa Boulevard, Westbrook Warrington Cheshire, WA5 7ZB, United Kingdom  
Phone: +44-1925-71-3000 Fax: +44-1925-71-3001

**Kawasaki Robotics GmbH**

[www.kawasakirobot.de](http://www.kawasakirobot.de)  
29 Sperberweg, 41468 Neuss, Germany  
Phone: +49-2131-34260 Fax: +49-2131-3426-22

**Kawasaki Machine Systems Korea, Ltd.**

[www.kawasakirobot.co.kr](http://www.kawasakirobot.co.kr)  
69BL-1LT, 638, Gojan-Dong, Namdong-Gu, Incheon, 405-817, Korea  
Phone: +82-32-821-6941 Fax: +82-32-821-6947

**Kawasaki Robotics (Tianjin) Co., Ltd.**

[www.kawasakirobot.cn](http://www.kawasakirobot.cn)  
Bldg 3, No.16, Xiang'an Road, TEDA, Tianjin 300457 China  
Phone: +86-22-5983-1888 Fax: +86-22-5983-1889

**Kawasaki Motors Enterprise (Thailand) Co., Ltd.**

(ROBOT DIVISION)  
[www.khi.co.jp/robot/th/](http://www.khi.co.jp/robot/th/)  
129 Rama 9 Road, Kwaeng Huay-Kwang, Khet Huay-Kwang, Bangkok 10310, Thailand  
Phone: +66-2-247-7935-8 Fax: +66-2-247-7934



**CAUTIONS TO BE TAKEN TO ENSURE SAFETY**

- For those persons involved with the operation / service of your system, including Kawasaki Robot, they must strictly observe all safety regulations at all times. They should carefully read the Manuals and other related safety documents.
- Products described in this catalogue are general industrial robots. Therefore, if a customer wishes to use the Robot for special purposes, which might endanger operators or if the Robot has any problems, please contact us. We will be pleased to help you.
- Be careful as Photographs illustrated in this catalogue are frequently taken after removing safety fences and other safety devices stipulated in the safety regulations from the Robot operation system.



ISO certified in Akashi Works.

**Kawasaki Robot**

*Medical and pharmaceutical robot*

**MCR**

*Japan & Asia*



Agent

\* Materials and specifications are subject to change without notice.

# A clean robot for medical and pharmaceutical application: The new solutions from KAWASAKI offering based on advanced technologies.

Robotics Automation is required in the pharmaceutical and medical industries to avoid a human error, a contamination risk or a risk of exposure to High Potency Active Pharmaceutical Ingredient, such as an anticancer drugs. MCR is a robot for pharmaceutical and medical application that was developed to meet these requirements.



## ● Key features

- 1 Human arm-like**  
Human arm-like joint configurations provide minimal dead space and allow robot to rotate and operate in constricted workspaces.
- 2 Sanitary features**  
Streamlined design features a smooth surface, high performance seals, and a chemical resistant epoxy paint finish to facilitate decontamination process.
- 3 Hollow wrist**  
Through-arm cable and tube technology eliminates cable interference. (The built-in cable specification should be defined separately.)
- 4 Cleanroom classification**  
Meets ISO Class 5 (Class 100 of US FED STD 209E) cleanroom standard.
- 5 Compact body**  
Short and compact arm design is ideal for narrow or confined spaces.

## ● Motion range & dimensions

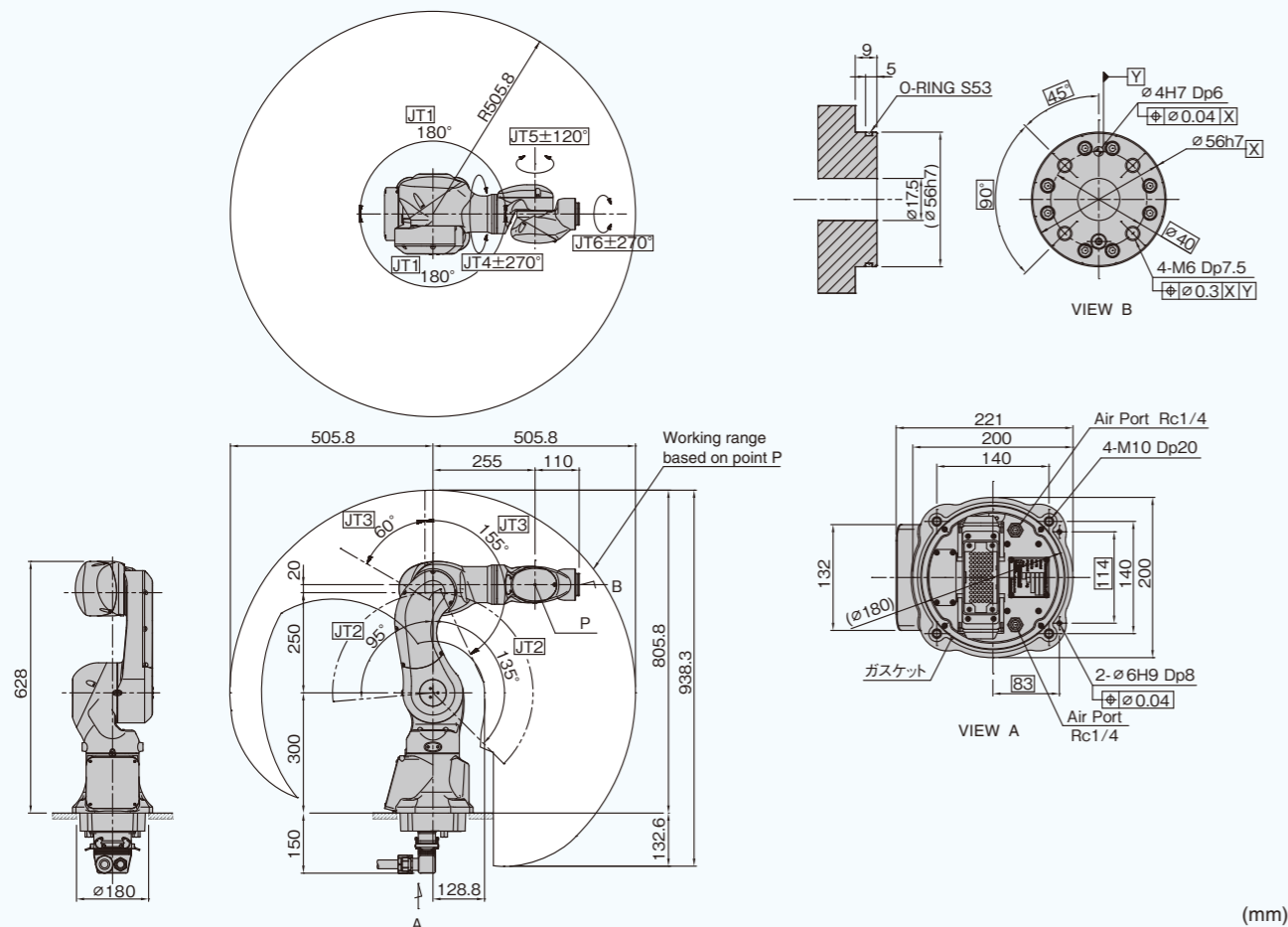

## ● Specifications

| Model                                  |                    | MC004N  |
|--|--------------------|---|
| Type                                   |                    | Articulated robot   |
| Degree of freedom (axes)               |                    | 6   |
| Max. payload (kg)                      |                    | 4   |
| Motion range (°)                       | Arm rotation (JT1) | ±180  |
|  | Arm out-in (JT2)   | +135 ~ -95  |
|  | Arm up-down (JT3)  | +60 ~ -155  |
|  | Wrist swivel (JT4) | ±270  |
|  | Wrist bend (JT5)   | ±120  |
|  | Wrist twist (JT6)  | ±270  |
| Max. speed (°/s)                       | Arm rotation (JT1) | 175   |
|  | Arm out-in (JT2)   | 180   |
|  | Arm up-down (JT3)  | 140   |
|  | Wrist swivel (JT4) | 700   |
|  | Wrist bend (JT5)   | 500   |
|  | Wrist twist (JT6)  | 350   |
| Moment (N·m)                           | Wrist swivel (JT4) | 8.5   |
|  | Wrist bend (JT5)   | 8.5   |
|  | Wrist twist (JT6)  | 4.0   |
| Moment of Inertia (kg·m <sup>2</sup> ) | Wrist swivel (JT4) | 0.2   |
|  | Wrist bend (JT5)   | 0.2   |
|  | Wrist twist (JT6)  | 0.1   |
| Positional repeatability (mm) *1       |                    | ±0.05   |
| Max. reach (mm)                        |                    | 505.8   |
| Mass (kg)                              |                    | 25  |
| Body color                             |                    | White 12-MTJ-500938 (epoxy paint)                                 |
| Installation                           |                    | Floor, Ceiling  |
| Cable connection                       |                    | Bottom  |
| Environmental condition                | Temperature (°C)   | 10 ~ 35   |
|  | Humidity (%)       | 35 ~ 85 (No dew, nor frost allowed)                               |
| Cleanliness                            |                    | ISO Class 5   |
| Integrated function                    |                    | Air piping (φ4×2) Through from the wrist flange, Port size: Rc1/4 |
| Power requirements (kVA) *2            |                    | 1.0   |
| Degree of protection *3                |                    | IP65 (Wrist: IP67)  |
| Matching controller                    |                    | E73   |

\*1: conforms to ISO9283 \*2: depends on the payload and motion patterns \*3: The flange must be closed in case of using the built-in piping.

## ● Specifications

| Model                     |                          | Standard   | Option           |
|---------------------------|--------------------------|--|------------------|
| Model                     |                          | E73  |                  |
| Dimensions (mm)           |                          | W500×D420×H259   |                  |
| Structure                 |                          | Enclosed structure / Indirect cooling system   |                  |
| Number of controlled axes |                          | 6  | Max. 8           |
| Drive system              |                          | Full digital servo system  |                  |
| Coordinate systems        |                          | Joint, Base, Tool  | Fixed tool point |
| Types of motion control   |                          | Joint/Linear/Circular Interpolated motion  |                  |
| Programming               |                          | Point to point teaching or language based programming  |                  |
| Memory capacity (MB)      |                          | 8  |                  |
| General purpose signals   | External operation       | Motor power off, Hold  |                  |
|                           | Input (Channels)         | 32   | Max. 96          |
|                           | Output (Channels)        | 32   | Max. 96          |
| Operation panel           |                          | E-Stop switch, teach/repeat switch, control power light (Cycle start, motor-on, hold/run, and error reset are activated from the teach pendant.) |                  |
| Cable length              | Teach pendant (m)        | 5  |                  |
|                           | Robot-controller (m)     | 5  |                  |
| Mass (kg)                 |                          | 30   |                  |
| Power requirements        |                          | AC200-240V ±10%, 50/60Hz, 1φ<br>Class-D earth connection (Earth connection dedicated to robots), leakage current: Maximum 100mA                  |                  |
| Environmental condition   | Ambient temperature (°C) | 0~45 (in vertical use 0~40)  |                  |
|                           | Relative humidity (%)    | 35~85 (no dew, nor frost allowed)  |                  |
| Teach pendant             |                          | TFT color LCD display with touch-panel, E-Stop switch, teach lock switch, Dead man's switch  |                  |
| Auxiliary storage unit    |                          | -  |                  |
| Interface                 |                          | USB, Ethernet (100BASE-TX), RS232C   |                  |